



Integrated Mixed-Signal Solutions

PRODUCT BRIEF

STMP3410

D-Major™ Audio Decoder with USB, LCD and Voice Record

FEATURES

- Decodes MP3 and WMA and is upgradeable to other digital music formats
- Supports WMA digital rights management and other security schemes
- Includes on-chip read only unique ID for digital rights management algorithms
- Hardware supports NAND Flash, SmartMedia, MMC, Secure Digital, CompactFlash, SDRAM, CD and IDE digital devices.
- Flexible, efficient on-chip DC-DC converter
- More than 35 hours of operation on a single AA battery (Alkaline 2850mAh or better)
- Designed to operate from many different battery configurations, including 1xAA, 1xAAA, 2xAA, 2xAAA, Lilon (2xAA, 2xAAA and Lilon configurations require 144-pin package)
- USB download interface
- LED/LCD Driver
- GPIO and button I/O controls
- Voice record in ADPCM format
- Volume control on record and playback
- Full analog mixer configuration
- <0.05% THD headphone driver, including anti-pop and short-circuit protection
- High performance 18-bit $\Sigma\Delta$ technology
- Line-in to Line-out SNR >90 dB
- Mac and Windows drivers, also supports USB-Mass Storage Class
- Interface to a host chip/processor (optional)
- Upgradeable firmware
- DSP maximum speed is 65 MHz
- Energy saving dynamic power management
- Bass and Treble control; configurable multiple band control
- FM radio input and control support
- Three analog line-level inputs: Line_In (stereo), FM_In (stereo, 144-pin package only), and Mic (mono)
- Offered in 100-pin TQFP, 144-pin TQFP, and 144-pin fpBGA packages

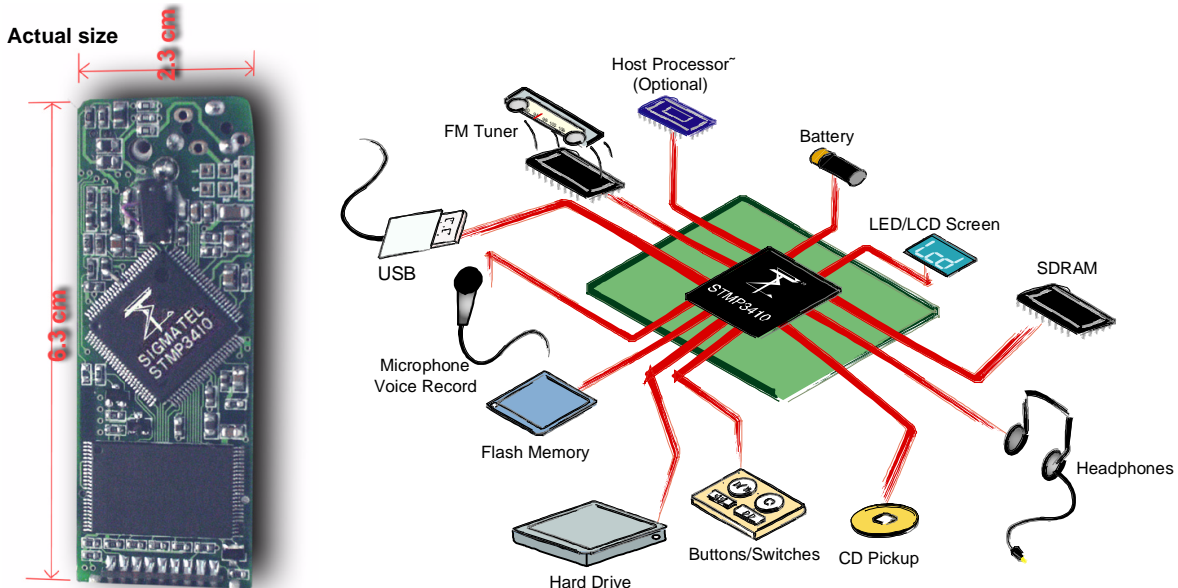

For designs as small as 14.5 cm²

STMP3410

D-Major™ Audio Decoder with USB, LCD and Voice Record



DESCRIPTION

SigmaTel's STMP3410 is a second generation single-chip highly-integrated digital music system solution for devices such as digital audio players, PDAs, and cell phones. It includes an audio decoder with a high performance DSP, ADPCM record capabilities and a USB interface for downloading music and uploading voice recordings. The chip also includes a mixer, DAC, ADC and provides interfaces to CD-DSPs, flash memory, LED/LCDs, button & switch inputs, headphones, FM radio input & controls and a microphone. The chip's highly programmable architecture supports MP3, WMA, and other digital audio standards. WMA digital rights management and other security schemes are also supported. The end-user can download music and also update firmware through a USB interface. For devices like PDAs and cell phones, STMP3410 can act as a slave chip to a host chip/processor.

The DAC includes a headphone driver to directly drive low impedance headphones. The ADC includes inputs for both microphone and analog audio in to support voice recording & FM radio integration features. SigmaTel's proprietary Sigma-Delta ($\Sigma\Delta$) technology achieves a DAC SNR in excess of 90 dB for high-quality audio playback.

The STMP3410 has low power consumption to allow long battery life and includes an efficient flexible on-chip DC-DC converter that allows many different battery configurations, including 1xAA, 1xAAA, 2xAA, 2xAAA and Lilon. In addition, the single-chip design and low pin count enables very small digital audio devices to be designed.

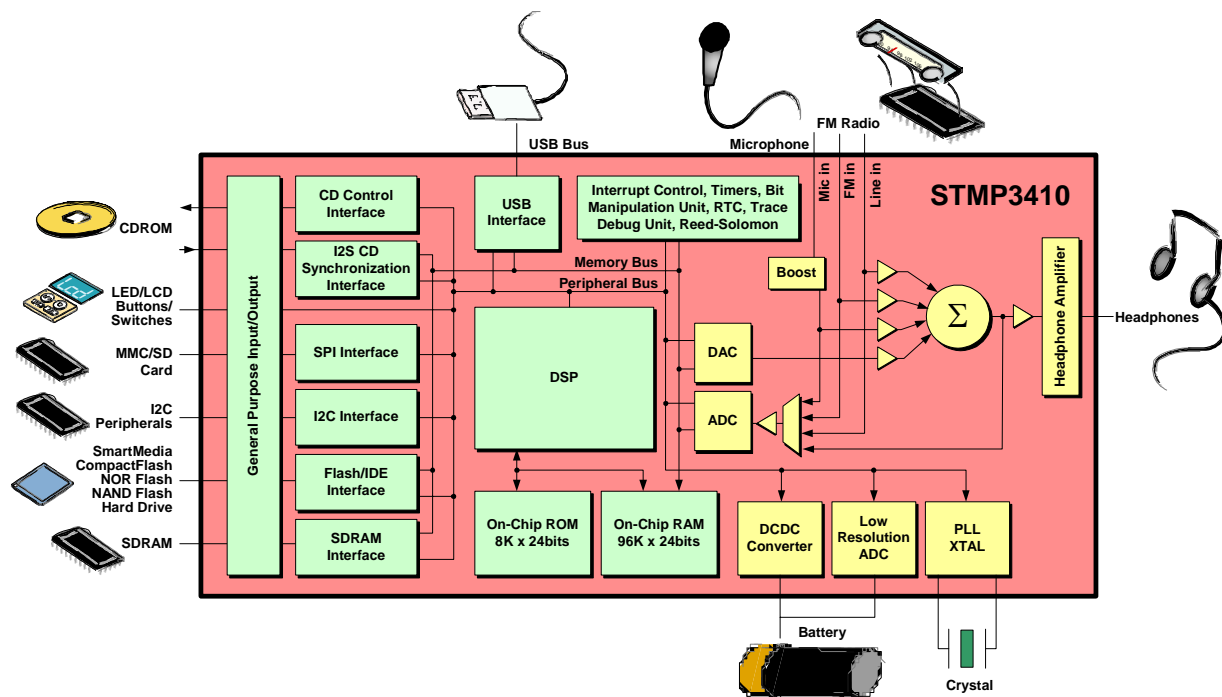

Figure 1. STMP3410 Block Diagram

ADDITIONAL SUPPORT

Additional product and company information can be obtained by going to the SigmaTel website at: www.sigmatel.com